

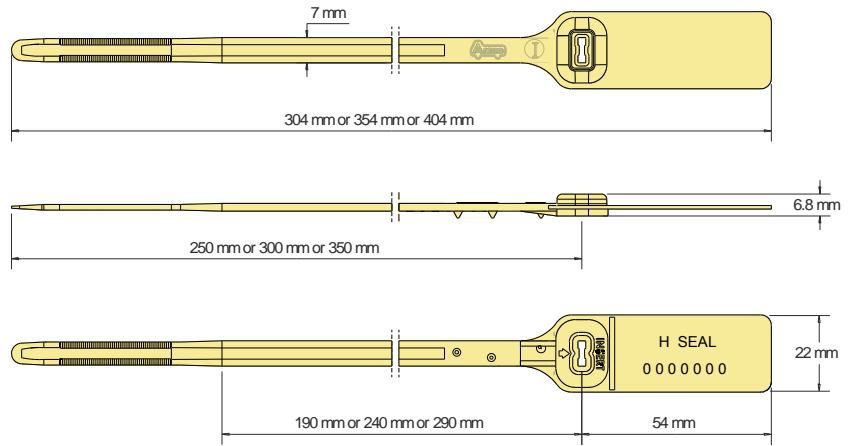

H SEAL Data Sheet

Acme Reg. No. 14041410



The Acme **H Seal** is a smooth ribbon, pull-tight seal manufactured from Polypropylene material. The design features rolled heat staking technology to secure the metal spring insert to the body, which provides clear evidence of tampering if forced open or cut. The seal can be manufactured with or without gripping spikes and label tag if required. This seal is suitable for many applications where strength is the requirement.

Technical Data

Recommended Applications

Airlines, Cargo, Trailers, Tankers, Rail & Sea Freight, Containers, Refineries, Warehouses, Cash bags, Postbags, Valves, Hatches, Lockers.

Material

Body - Polypropylene
Insert - Spring Stainless Steel

Available Operating Lengths

- (L1) 25cm (overall 30.4cm)
- (L2) 30cm (overall 35.4cm)
- (L3) 35cm (overall 40.4cm)

Strap Width

7mm

Tag Marking Dimensions

22mm x 45mm

Average Breaking Strength

55kg

Marking

- Laser or Foil marking
- Consecutively numbered as standard
- Optional Customer name/logo
- Optional Laser Barcoding

Colours

- Foil marked: red, blue, green, yellow, orange, black, white.
- Laser or Foil marked: pastel shades of pink, blue, green, yellow, peach, also black and white.
- Other colours may be available on request.

Packaging

- Standard Packaging : 10 per mat and 1,000 seals/carton
- Carton Dimensions : (L1) - 47cm x 33.5cm x 19cm
- : (L2) - 47cm x 38.5cm x 19cm
- : (L3) - 47cm x 43.5cm x 19cm
- Carton weight : (L1) - 5.55kg/carton
- : (L2) - 6.20kg/carton
- : (L3) - 7.02kg/carton